

	MODEL NUMBER: PDI-886C	Document Number: PD196-189R2
	Installation Instructions	Page 1 of 2

Scope:

Installing the PDI-886C floor mount (Basic) instructions.

For more detailed anchoring instructions, please see document PD196-061, which can be downloaded from the pdiarm.com website. The link is <http://www.pdiarm.com/support/downloads/PDF/PD196161R1.pdf>

NOTE: The mounting anchors (3/8 diameter) are not supplied by PDI. The required mounting anchors must meet local building code requirements.

Tool List:

1. Safety glasses/goggles
2. 1/8" hex key (for the pilfer proofing screw).
3. Concrete drill
4. Particle mask that is rated for concrete dust.

Safety Steps:

1. Always wear safety glasses/goggles to prevent injury from debris.
2. Follow the installation/removal instructions for you existing products.

PROCEDURE:

Step 1:

Locate and lay out the bolt pattern for the mounting anchors.

Step 2:

Follow the manufacturer's instructions for installation of the chosen mounting anchors.

Drill the anchor holes to manufacturer's specification.

Tighten the anchors to the manufacturer's spec for the chosen anchor.

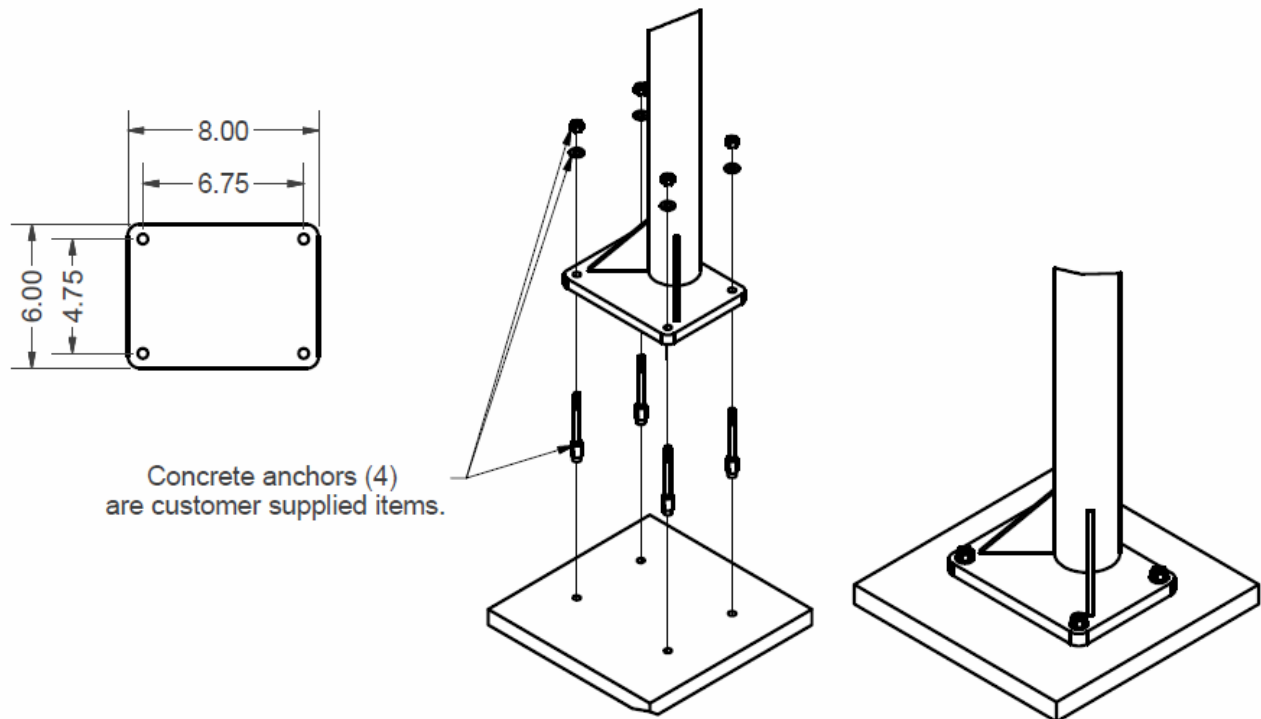

	MODEL NUMBER: PDI-886C	Document Number: PD196-189R2
	Installation Instructions	Page 2 of 2

Step 3:

Use the 1/8" hex key to remove the pilfer proofing screw and spacer.

Step 4:

Install the arm (sold separately) into the floor mount, taking care to properly align the base pin with the bushing, to prevent damage to the bushing during installation.

Step 5:

Use the 1/8" hex key to reinstall the pilfer proofing screw and spacer. Rotate the arm from side to side to verify that it moves smoothly and does not bind on the pilfer proofing screw. Lift up on the arm to confirm that the arm cannot be removed while the pilfer proofing screw is installed.

